

T.I.P. (Technical Information Package)

Number: 107

Subject: Hood Prop

Model Year(s) Effected: 1936—1946

Model(s) Effected: Chevrolet® and GMC® Trucks

All information, illustrations and specifications are based on the best information available at the time of publication. The author cannot guarantee the accuracy of the information contained in this publication. Corrections are welcomed, and can be submitted to randy74@charter.net.

INTRODUCTION

On early Chevy and GMC trucks with 4-piece hoods, one question often is raised: How to securely hold the hood open? There is nothing more aggravating (and possibly dangerous) than to have the hood slip off the cowl and come slamming down.

The other solution is to open the hood completely and rest it on the hood panel on the other side. This can scratch the hood panels, and does not allow both sides of the hood to be opened at the same time.

The best solution is to prop the hood open. From all indications, the hood prop shown in this document may have been a factory item, but in many cases these have been lost over the years.

When the hood is opened, the prop mounted on the core (radiator) support rod is pivoted up, and the hood latch rod is placed in the notch at the end of the prop.

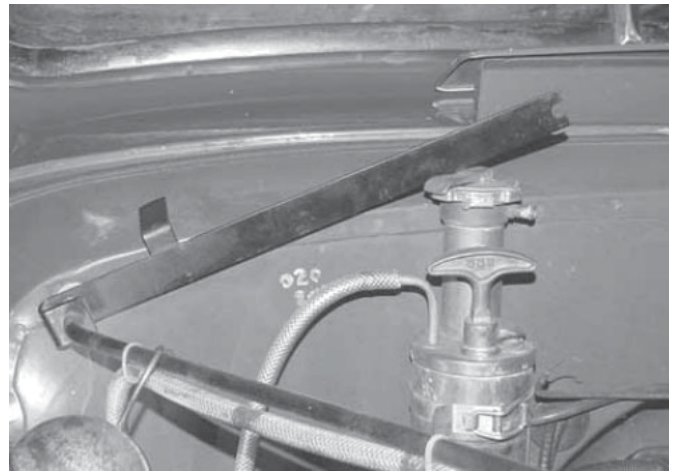

A460179A (J.H. PROFFIT)

Figure 2: Hood Prop - Storage Position

When lowering the hood, the hood prop is pivoted in. The tab welded on the arm will rest against the cowl to hold it in place when not in use.

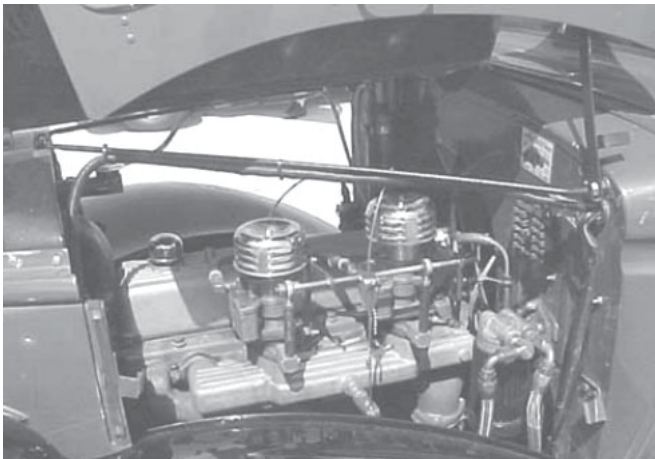

A460178A (J.H. PROFFIT)

Figure 1: Hood Prop - Supporting Hood

Chevrolet is a registered trademark of the Chevrolet Motor Division of the General Motors Corporation.

GMC is a registered trademark of the GMC Truck Division of the General Motors Corporation.

INSTALLATION

Note: In some applications, items mounted high on the firewall may not allow the hood prop to rest against the firewall when pivoted to the storage position.

The hood prop is mounted on the core support rod, and is held from moving front-to-rear by a jam nut in the opening formed at the end of the hood prop arm.

To install the hood prop (Figure 3):

Note: Before removing the core support rod, record the amount of threads exposed beyond the outer (engine side) nut. This will provide a starting point for adjusting the hood during re-assembly.

1. Remove the hood and core (radiator) support rod.
2. Remove the outer nuts and flat washers from the core support rod. Save all hardware.
3. Insert a 7/16-20 jam nut into the opening formed at the end of the hood prop arm. Place the hood prop and jam nut onto the threaded ends of the core support rod. Thread the jam nut onto the rod.
4. Install the outer nuts and flat washers on the core support rod, adjust the nut to expose the same amount of threads as recorded before removal.
5. Repeat Steps 3 and 4 to install the hood prop on the other side of the core support rod.

Note: Hold the hood props in position while installing the core support rod, this may require an assistant.

6. Install the core support rod. Do not tighten the inner and outer core support nuts until the hood position (gap) is correct.
7. Install the hood. Adjust the hood gap as needed, turning the outer core support nuts in or out as needed.

Note: Some slight front-to-back position adjustment of the hood prop may be required. Adjust the jam nut as required.

8. Tighten the inner and outer core support nuts.

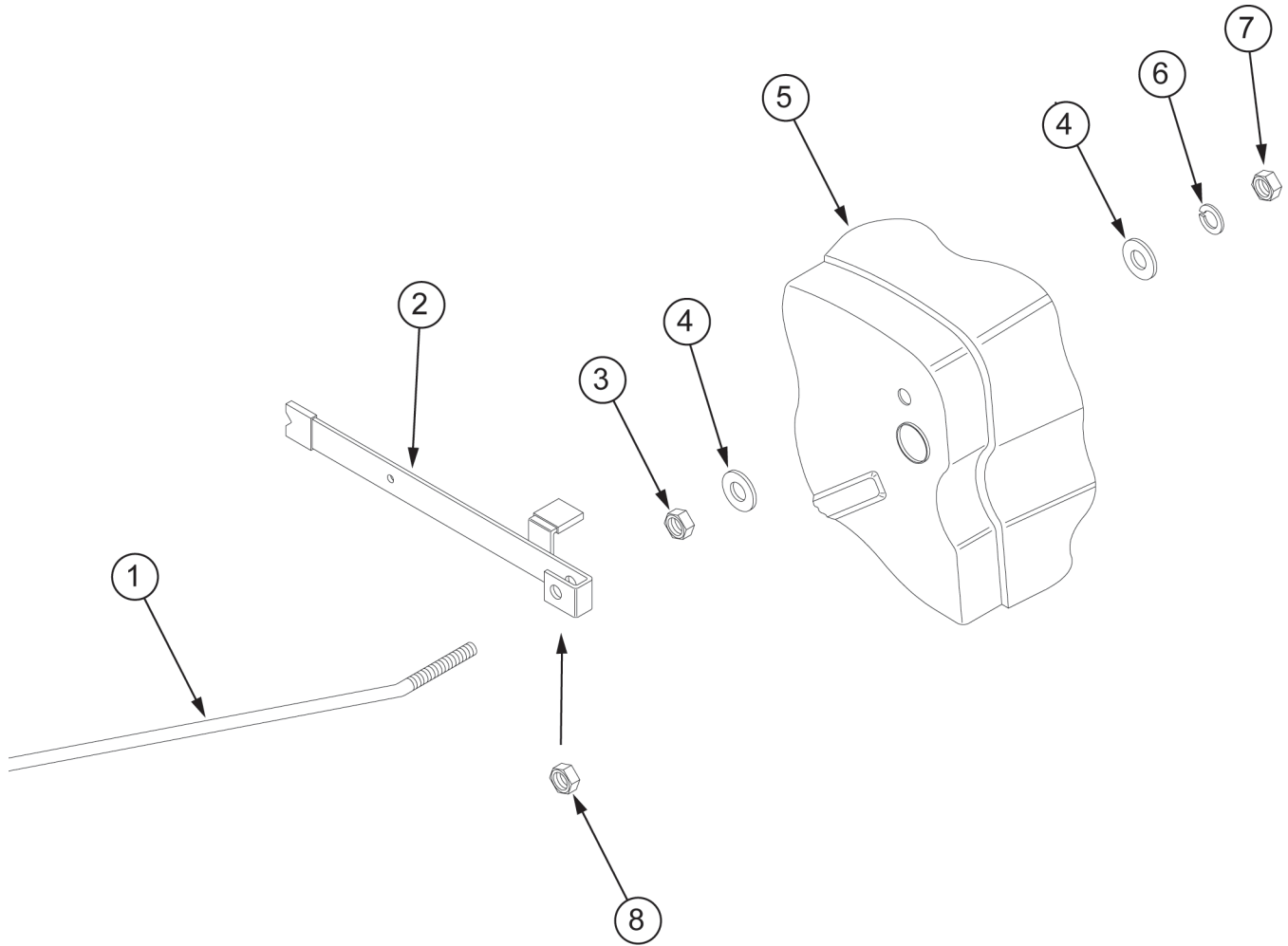

Figure 3: Installation Drawing

A460133A (R. BAUMANN)

- 1. Core Support Rod
- 2. Hood Prop (Left)
- 3. Nut, Outer
- 4. Flat Washer (2 Used)
- 5. Cowl
- 6. Split-Lock Washer
- 7. Nut, Inner
- 8. Jam Nut, 7/16-20

PARTS AND ASSEMBLY DRAWINGS

The following drawings are provided as a service to fellow hobbyists to understand and/or reproduce an existing part. Actual dimension may have varied from model year to model year.

The author makes no claims to design, nor guarantees the performance and/or safety of the parts and assemblies described.

Note: the original hood props were not coated with a plastic coating in the areas that come into contact with the cowl and hood. The plastic coating can be added to reduce the chance of paint damage due to metal-to-metal contact.

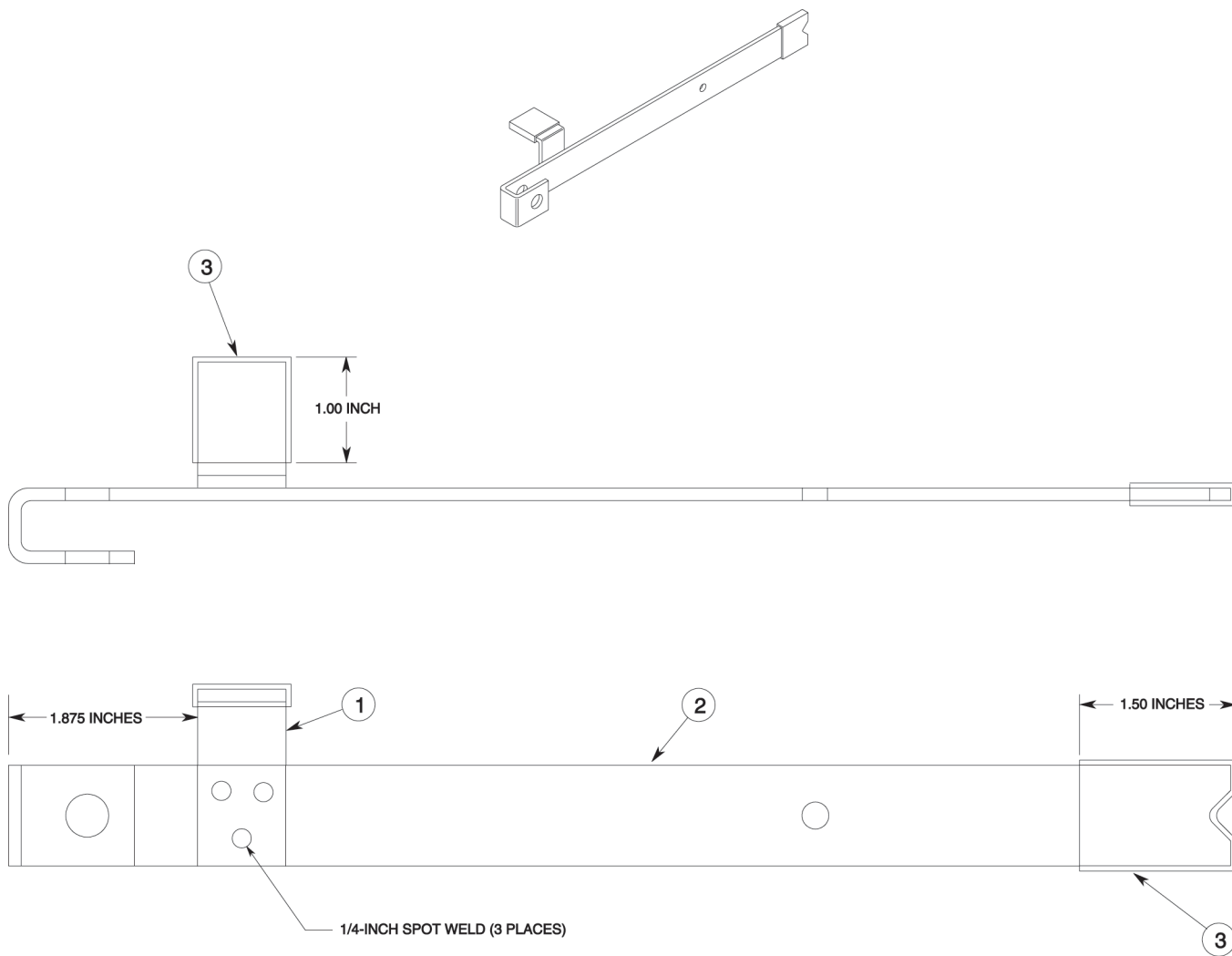

PLASTI DIP - BLACK (FLEXIBLE RUBBER COATING)
 PDI, INC.
 P.O. BOX 130
 CIRCLE PINES, MN. 55014
 LOCAL VENDOR: ACE HARDWARE
 EQUIVALENT PRODUCT MAY BE SUBSTITUTED

ITEM	PART DESCRIPTION	PART No.	QTY.
1	HOOD PROP STOP	P4600052	1
2	HOOD PROP ARM	P4600051	1
3	PLASTI DIP (SEE NOTE)	NONE	A/R

P46A0004 (R. BAUMANN)

Figure 4: Hood Prop Assembly—Right

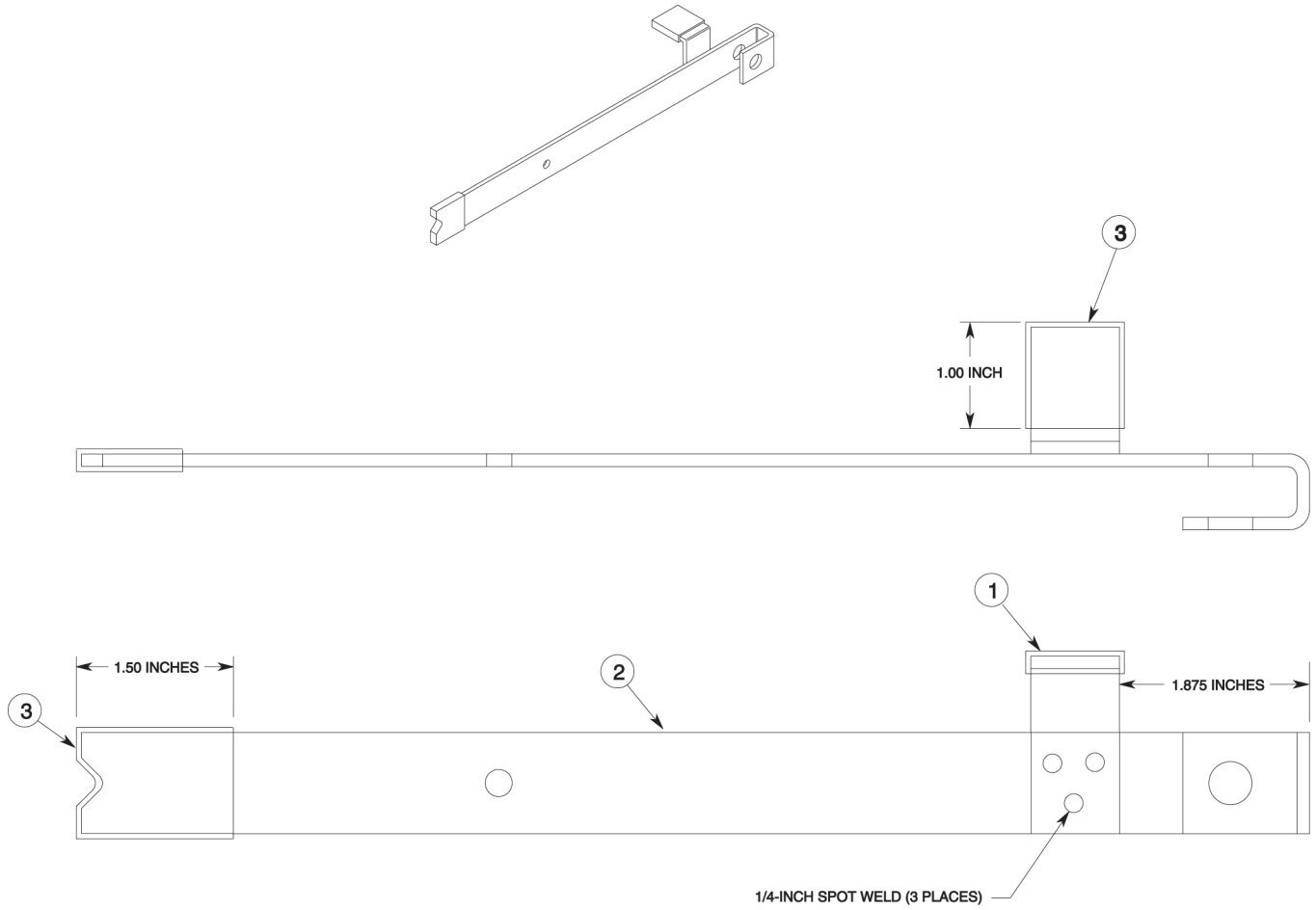

PLASTI DIP - BLACK (FLEXIBLE RUBBER COATING)
 PDI, INC.
 P.O. BOX 130
 CIRCLE PINES, MN. 55014
 LOCAL VENDOR: ACE HARDWARE
 EQUIVALENT PRODUCT MAY BE SUBSTITUTED

ITEM	PART DESCRIPTION	PART No.	QTY.
1	HOOD PROP STOP	P4600052	1
2	HOOD PROP ARM	P4600051	1
3	PLASTI DIP (SEE NOTE)	NONE	A/R

P46A0005 (R. BAUMANN)

Figure 5: Hood Prop Assembly—Left

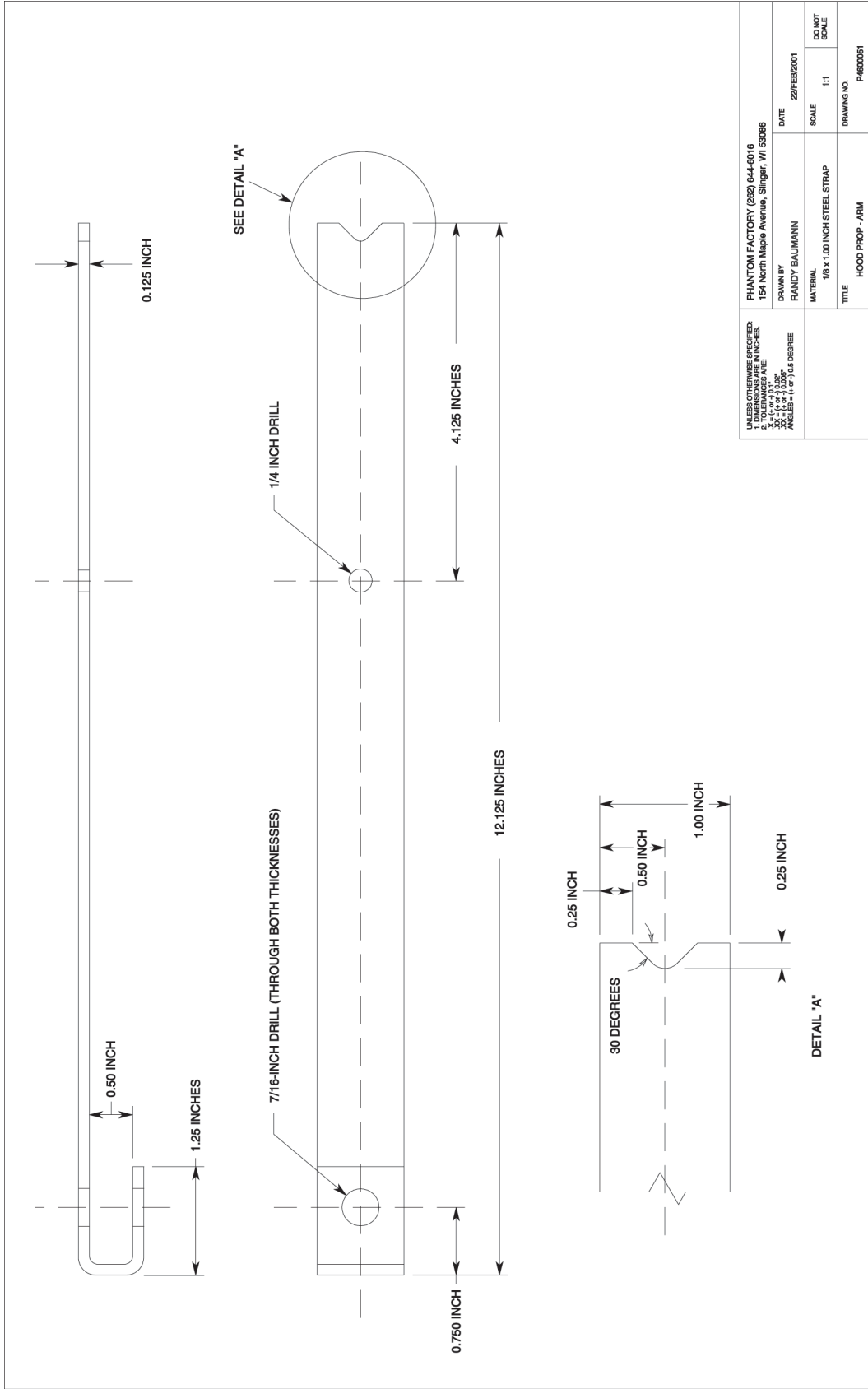

P4600051 (R. BAUMANN)

Figure 6: Hood Prop Arm

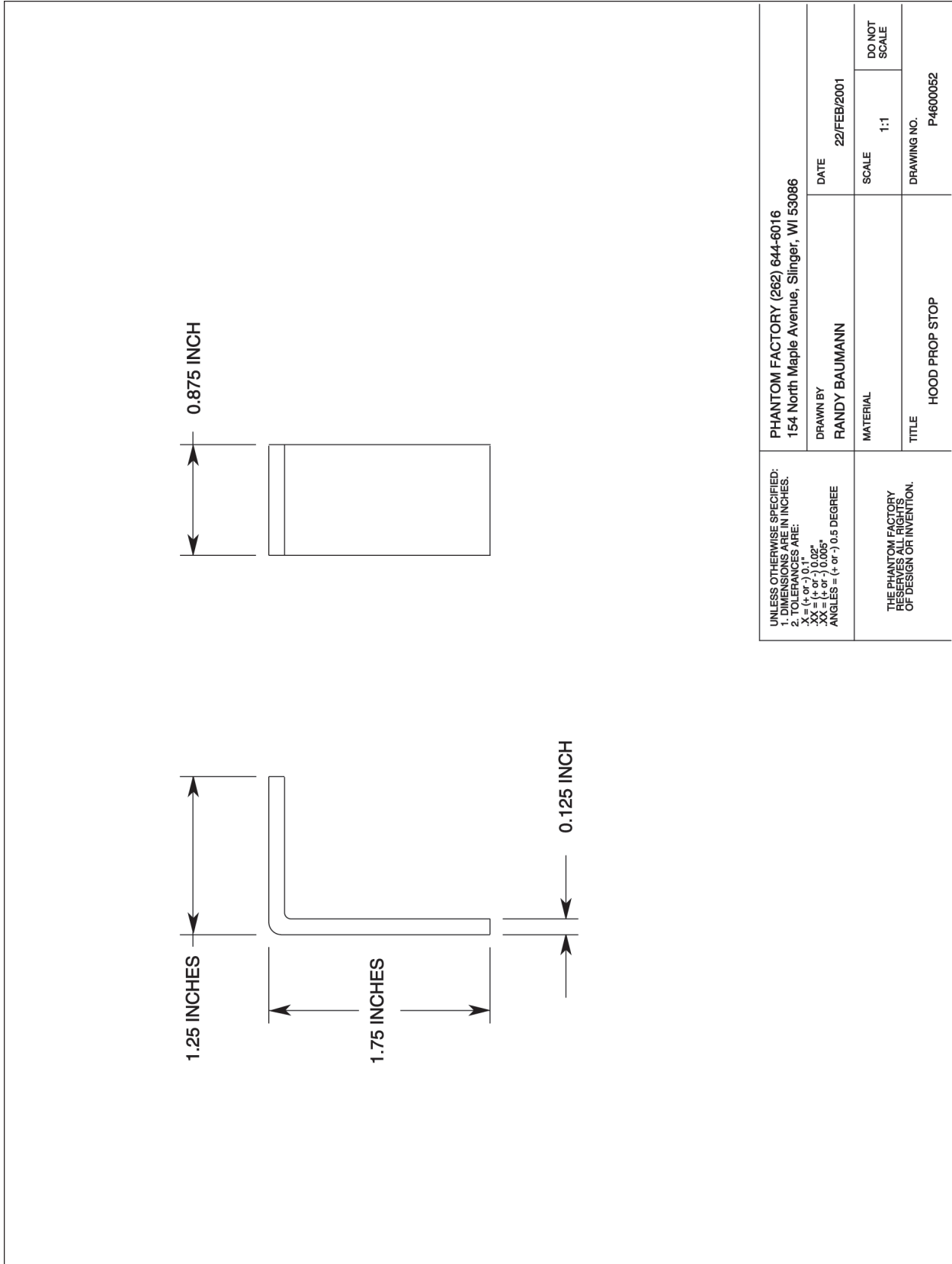

UNLESS OTHERWISE SPECIFIED: 1. DIMENSIONS ARE IN INCHES. 2. TOLERANCES ARE: X = (+ or -) 0.1 .XX = (+ or -) 0.02" .XX = (+ or -) 0.005" ANGLES = (+ or -) 0.5 DEGREE	PHANTOM FACTORY (262) 644-6016 154 North Maple Avenue, Slinger, WI 53086		DATE	22/FEB/2001
	DRAWN BY RANDY BAUMANN		SCALE	1:1
THE PHANTOM FACTORY RESERVES ALL RIGHTS OF DESIGN OR INVENTION.		MATERIAL HOOD PROP STOP		DO NOT SCALE DRAWING NO. P4600052

Figure 7: Hood Prop Stop

P4600052 (R. BAUMANN)